

# SL27M rullo

## 2. technical drawings

comprehensive drawing with component codes

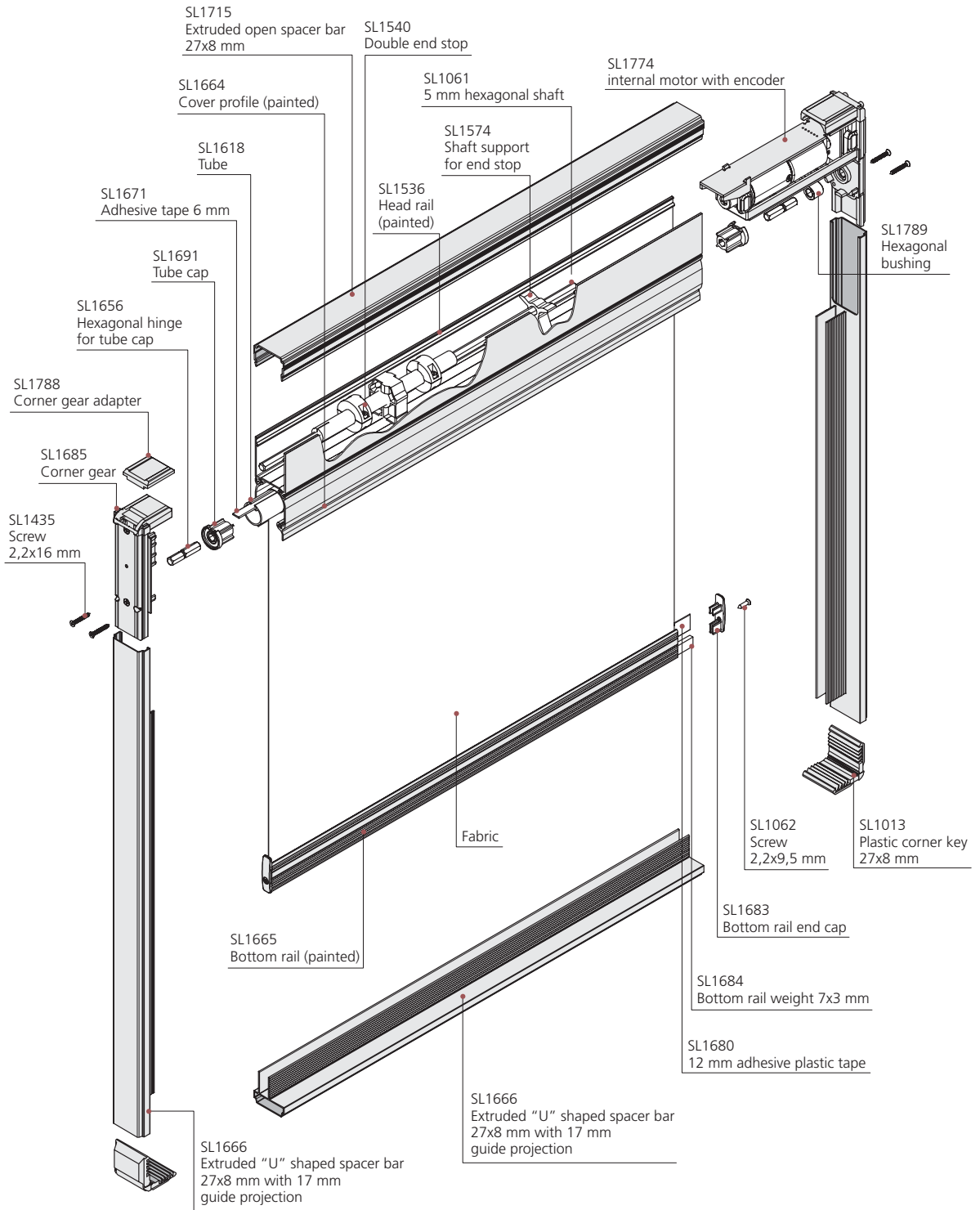

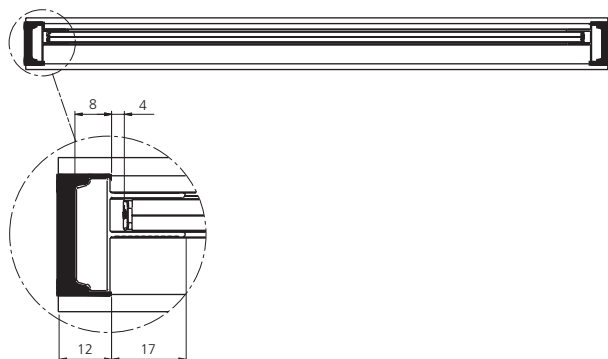
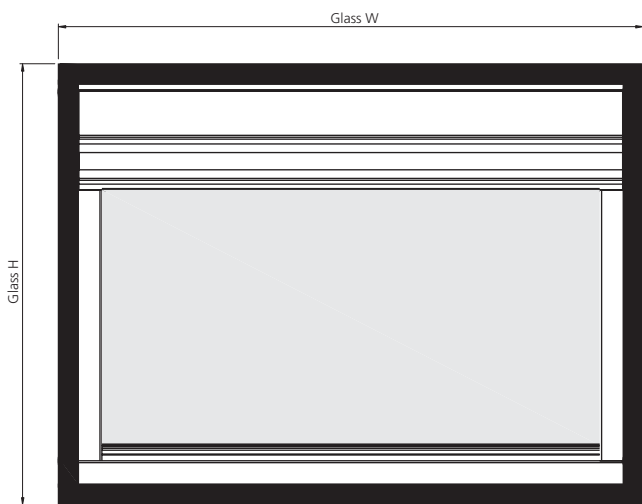

EXTRUDED "U" SPACER BAR 27X8 mm  
WITH 17 mm GUIDE PROJECTION

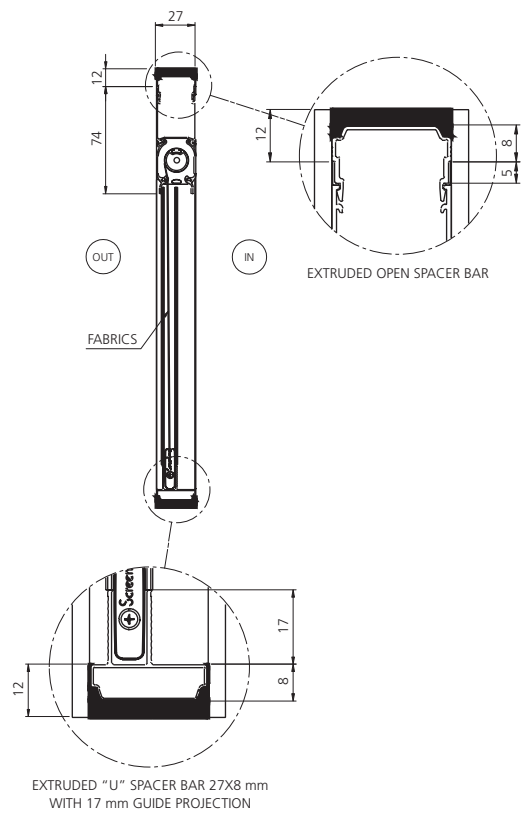

EXTRUDED "U" SPACER BAR 27X8 mm  
WITH 17 mm GUIDE PROJECTION